

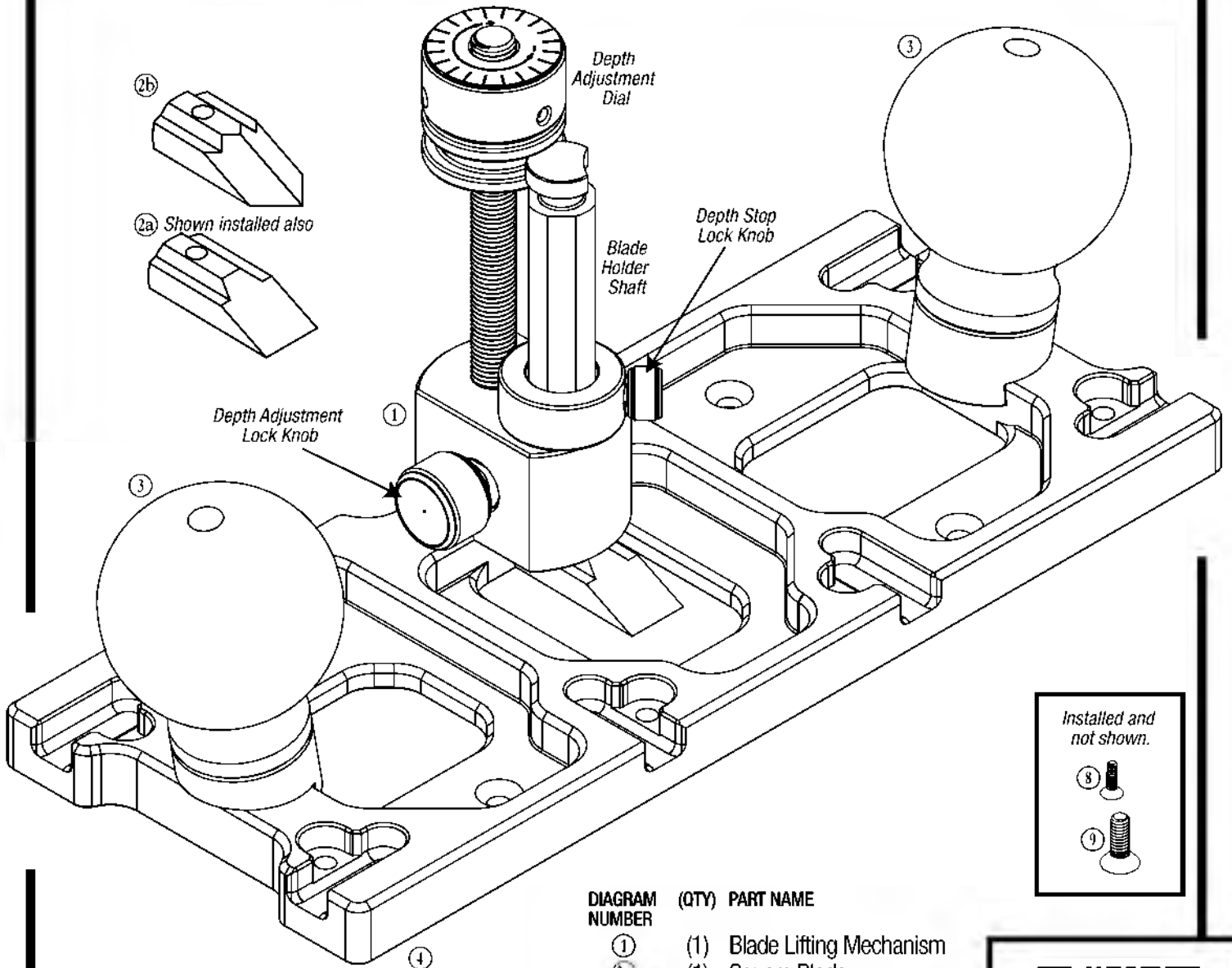

Blue Spruce
TOOLWORKS

Router Plane



Installed and
not shown.

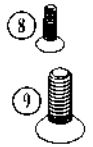

DIAGRAM NUMBER	(QTY)	PART NAME
①	(1)	Blade Lifting Mechanism
②a	(1)	Square Blade
②b	(1)	Spearpoint Blade
③	(2)	Blue Spruce Handles
④	(1)	Plane Base
⑤	(1)	5/64" Hex Key
⑥	(1)	1/8" Hex Key
⑦	(1)	5/32" Hex Key
⑧	(1)	Small Flat Head Socket Cap Screw, #6-32 x 1/2"
⑨	(2)	Large Flat Head Socket Cap Screw, 1/4-20 x 3/4"



Scan the QR code above
to watch the video
or visit
bluesprucetoolworks.com

If you think you're missing anything, email us at mailroom@bluesprucetoolworks.com.
You can also call us at 877-828-0332 from 9:00 a.m. to 4:00 p.m. EST Monday - Friday.

THANK YOU for your purchase of the *Blue Spruce Toolworks Router Plane*. No matter how dialed in your machinery setup is or how steady your hand, it's nearly impossible to get perfectly parallel, flat-bottomed joinery straight off the cut. The sole of the Router Plane is machined flat and the blade is held parallel to the sole. Combined with precise depth control and flexibility in blade direction, your pockets, mortises, rabbets, grooves, and dados will always come out flat, smooth, and at the right depth.

I. ASSEMBLY

The base of the Router Plane has three mounting locations for the ① Blade Lifting Mechanism and the ③ Handles. **FIGURE A**. Each setup has its advantages, see **Part II-Page 4-E** for choosing your desired setup.

Your Router Plane comes with two Blades, one ②a Square and the other a ②b Spearpoint. The Square Blade works well for most applications while the Spearpoint Blade is good for cleaning up mortises or pockets.

1. Install the ① Blade Lifting Mechanism in your desired mounting location and orientation using a ⑨ Large Flat Head Socket Cap Screws and the ⑦ 5/32" Hex Key. **FIGURE B**.
2. Install one of the ② Blades onto the Blade Lifting Mechanism using the ⑧ Small Flat Head Socket Cap Screw and ⑤ 5/64" Hex Key. **FIGURE B**.
3. Install the ③ Handles in the remaining locations using using a ⑨ Large Flat Head Socket Cap Screws and the ⑦ 5/32" Hex Key. **FIGURE B-1**.
4. The end of the Blade Holder Shaft is angled. When the tip of the Blade touches the material, there should be a small gap at the back of the Blade. If the back touches first, flip the blade 180°. **FIGURE C**.

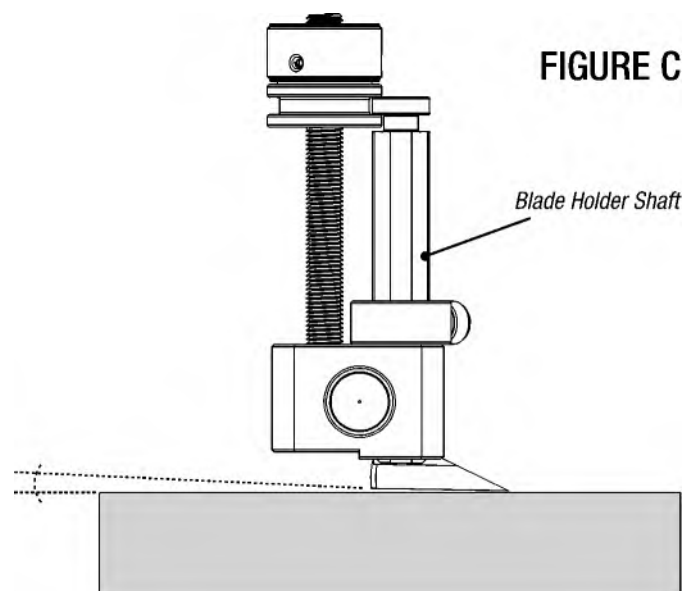
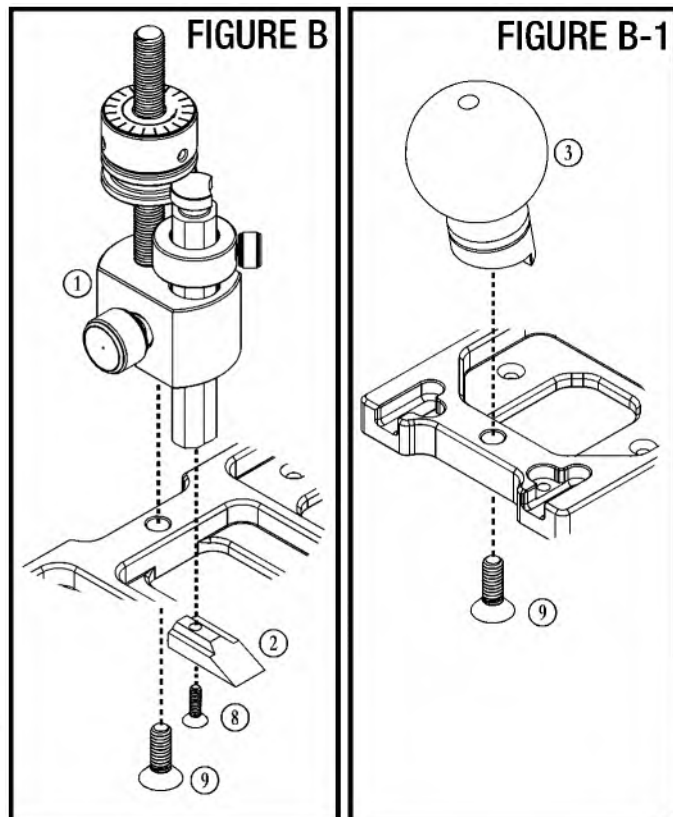
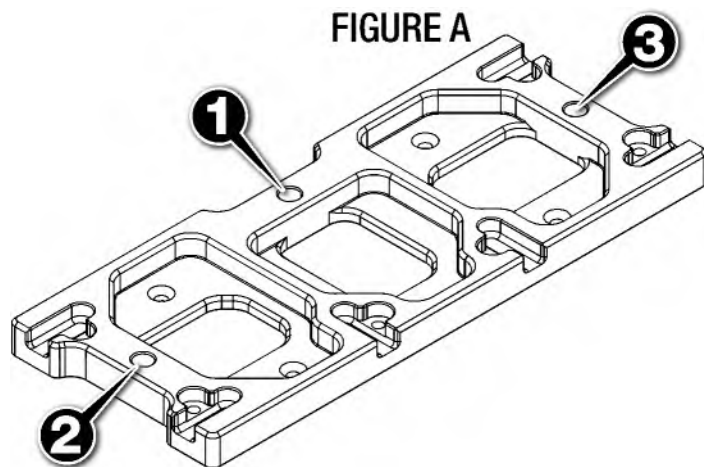

II. SETUP & USE

A. DEPTH ADJUSTMENT

1. Loosen the Depth Adjustment Lock Knob. **FIGURE D.**
2. To lower the Blade, spin the Depth Adjustment Dial clockwise.
To raise the Blade, spin the dial counter-clockwise.

FIGURE D-1.

NOTE

The depth adjustment is controlled by a 1mm-pitch screw. The Depth Adjustment Dial features helpful indicator marks for gauging relative depth adjustments. Each tick mark represents about .002", or 1/20 mm, vertical adjustment.

3. Re-tighten the Depth Adjustment Lock Knob before use.

B. DEPTH STOP

1. The Depth Stop can be used to set a critical depth or for repeatable depths.
2. Crack loose the Depth Stop Lock Knob. If it is locked too tight you can use the 1/8" Hex Key.
3. Using a setup block (sold separately), workpiece of a known dimension, or layout lines, elevate the sole of the Router Plane and lower the Blade to the desired depth. **FIGURE E.**
4. Firmly tighten the Depth Stop Lock Knob. For more leverage when tightening, use the 1/8" Hex Key.

C. ROTATING THE BLADE HOLDER SHAFT

1. The Blade Holder Shaft has four flats machined at each 90° which allows the Depth Adjustment Lock Knob to square the Blade and the Depth Stop a surface to clamp against.
2. The Blade can be rotated by loosening the Depth Adjustment Lock Knob two full turns and rotating the Blade Holder Shaft. **FIGURE F.**
3. When tightening the Depth Adjustment Lock Knob, you may need to nudge the blade in the right direction to properly engage the auto-squaring wedge clamps.

FIGURE E

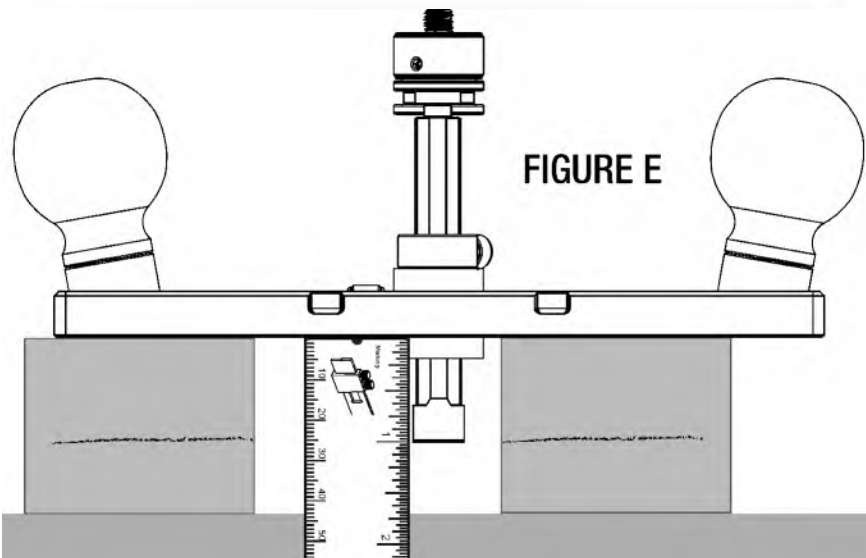

Depth Adjustment Dial

FIGURE D

Blade Holder Shaft

Depth Stop Lock Knob

Depth Adjustment Lock Knob

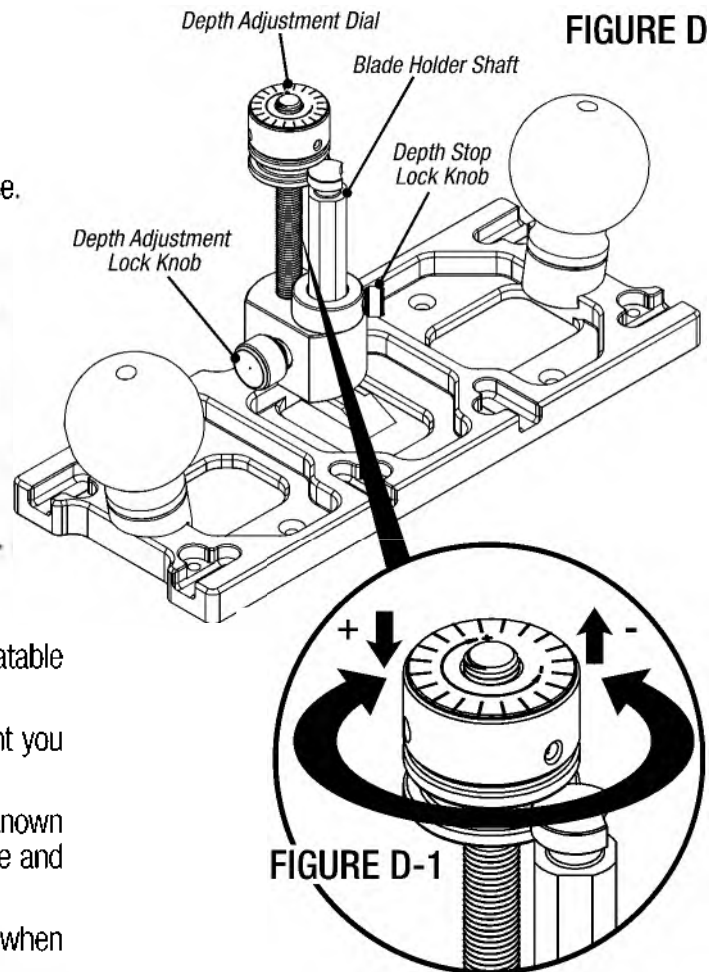
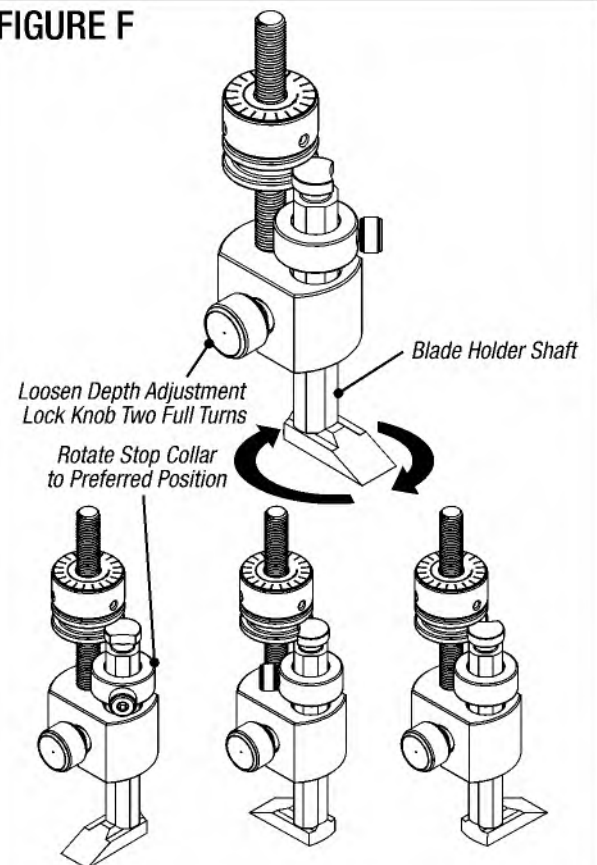

FIGURE D-1

FIGURE F



D. REMOVING THE BLADE HOLDER SHAFT

1. As an option, you can remove the Blade Holder Shaft for use when sharpening the Blade or for removing the Depth Stop Collar.
2. Start by loosening the Depth Adjustment Lock Knob two full turns.
3. Crack loose the Depth Stop Lock Knob using the 1/8" Hex Key.
4. Rotate the Blade until the cut-out at the top of the Shaft aligns with the Depth Adjustment Dial and the Shaft can drop through the bottom. **FIGURE G.**
5. To re-assemble, follow these steps in reverse.



PRO TIP

If you prefer, you can flip the Depth Lock Knob to the right side by removing the Blade Holder Shaft, sliding out the Depth Adjustment Lock Knob assembly, and re-installing in the other side. Ensure the wedges face the Blade Holder Shaft. **FIGURE G-1.**

E. BLADE POSITIONS

There are three locations and six positions the Blade Lifting Mechanism may be installed. Each setup has its advantages for different operations. **FIGURE H.**

LOCATION 1

1. If you've ever used a router plane, you'll recognize the Blade in **Location 1**.
2. **With the Blade facing inwards**, you get support on all four sides of the Blade. Whether pulling or pushing, the tool is balanced for grooves and short dados. **FIGURE I.**
3. **With the Blade facing outwards**, there's plenty of sole behind the Blade and no obstructions in front of the Blade. You can plane into a stopped groove or pocket corner.

LOCATION 2

1. **With the blade facing inwards**, you maximize sole in front of the blade. Traditional router planes often require equal-thickness parts to straddle the workpiece when working on a long tenon. With over 6" of bearing surface in front of the blade, you can reference the face of the workpiece.
2. **With the blade facing outwards**, you can clean up pockets. Or, turn the blade 90° and engage the cutter from the outside of the workpiece, reducing edge chip-out. **FIGURE J.**

LOCATION 3

1. **Location 3** is the mirror position of Location 2, but now the center handle is on the left. This may be more comfortable for left-handed users or when working around obstructions.

FIGURE G

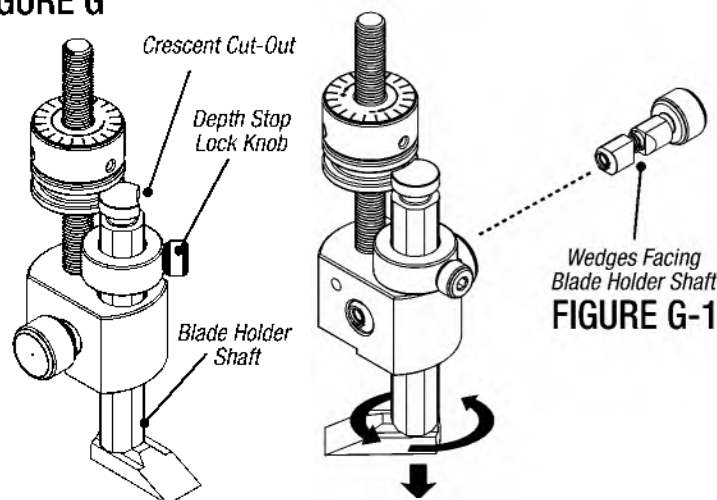

FIGURE H

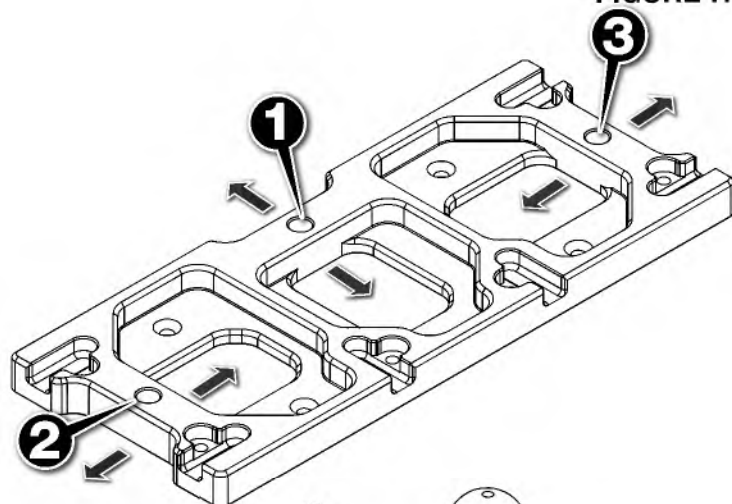

FIGURE I

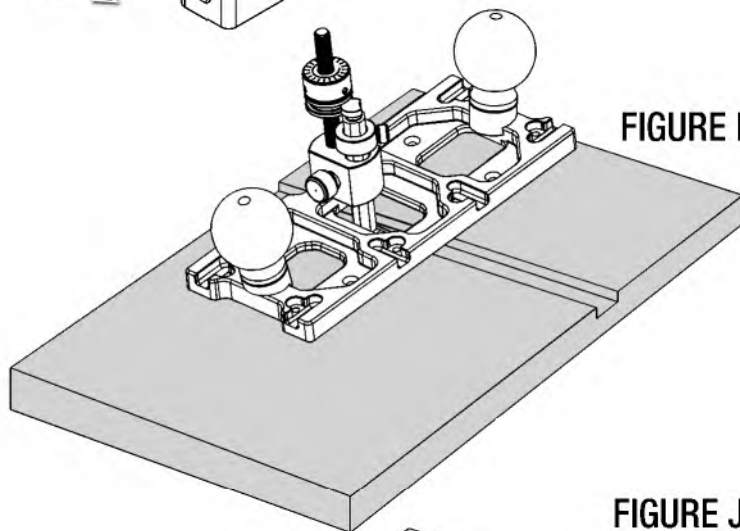
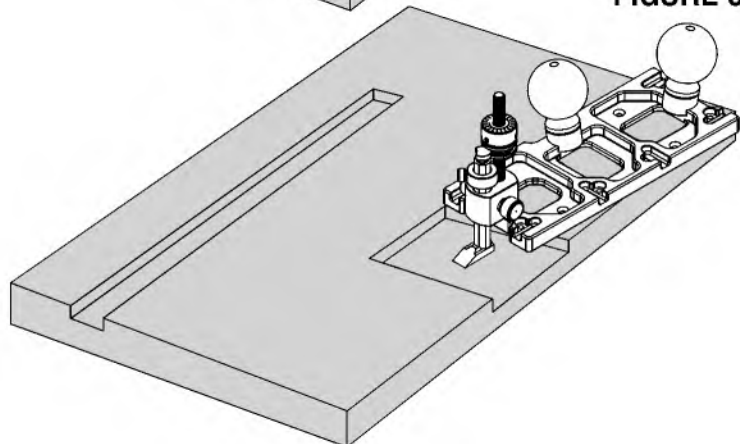

FIGURE J



OPTIONAL FENCE ATTACHMENT SKU: BSTWRP-F

DIAGRAM NUMBER (QTY) PART NAME

- ⑩ (1) Phenolic Fence Plate
- ⑪ (2) Guide Rods
- ⑫ (2) Guide Rod Clamps
- ⑬ (2) Knurled Knobs
- ⑭ (2) Flat Head Socket Cap Screws, 10-32 x 1/2"
- ⑮ (4) Socket Head Cap Screws, 8-32 x 3/8"
- ⑯ (1) 9/64" Hex Key

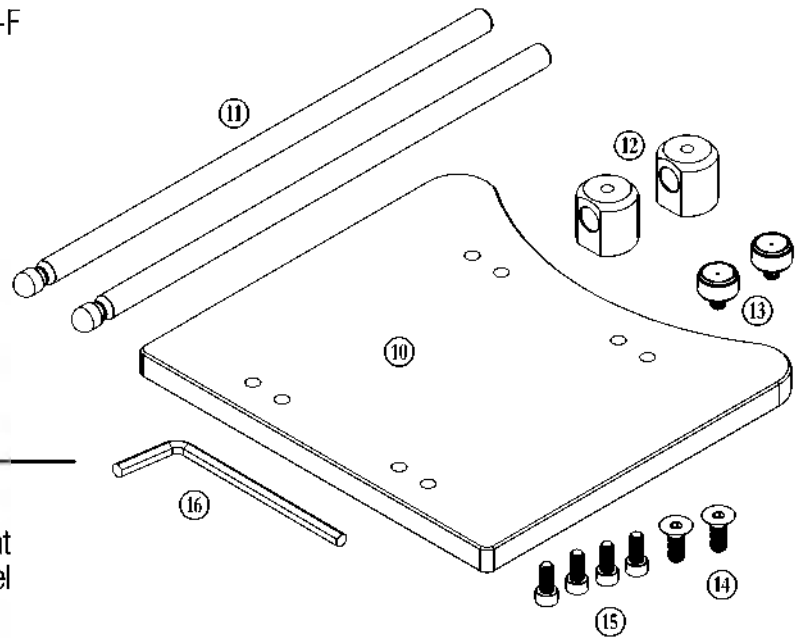

ASSEMBLY OF THE FENCE ATTACHMENT

1. The *optional* Fence Attachment gives you a straight and two-point curved reference for perfectly parallel inlays and long grooves. **FIGURE K.**
2. Similar to the Lifting Mechanism, the Fence can be installed in three locations on the Base. **FIGURES L, L-1, L-2, L-3.**

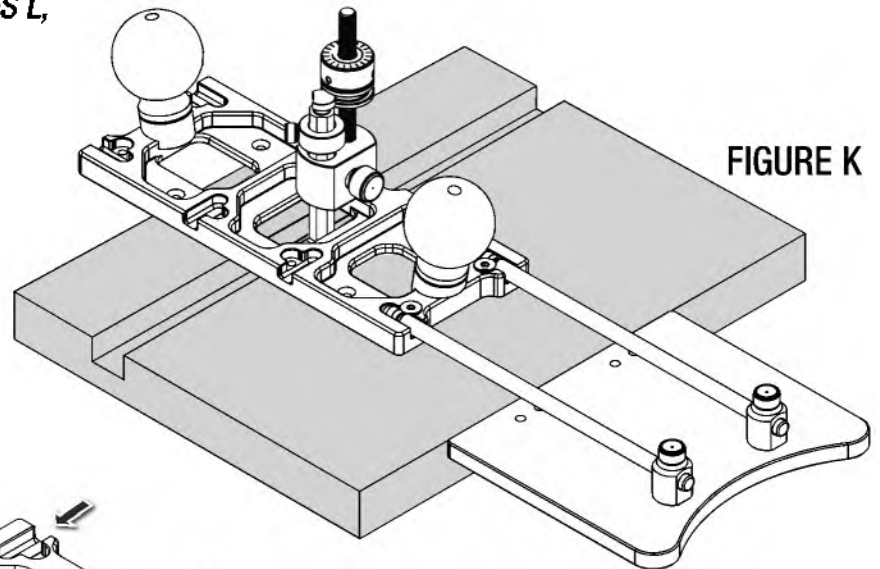

FIGURE K

FIGURE L

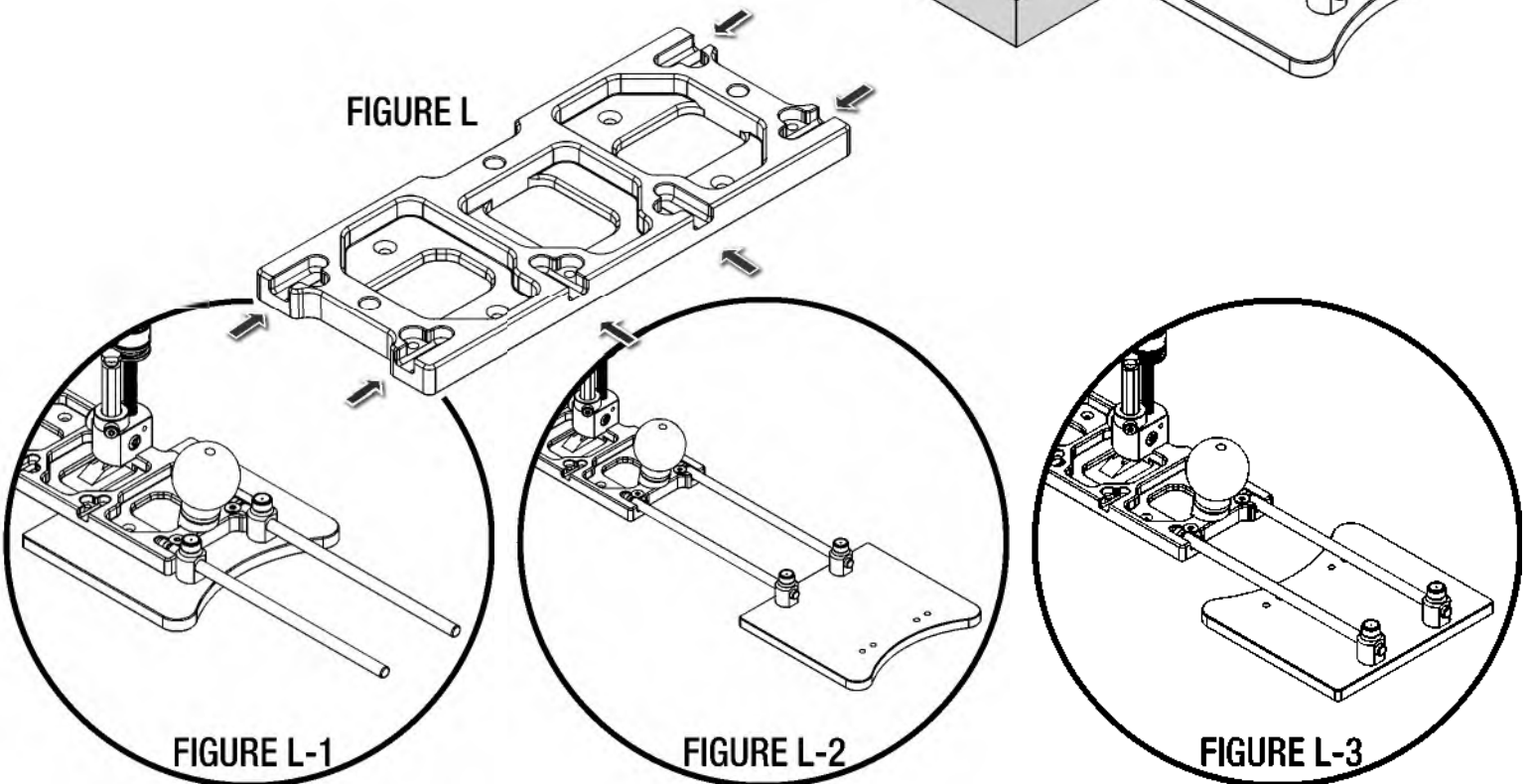
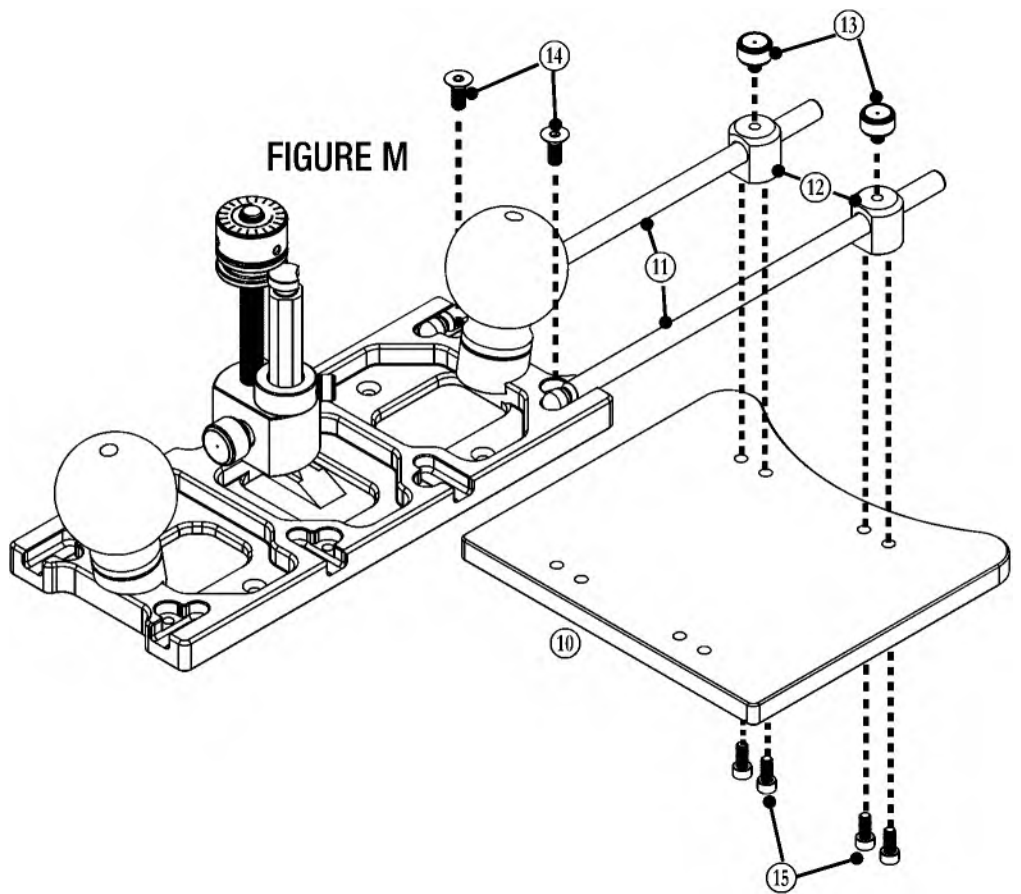

FIGURE L-1

FIGURE L-2

FIGURE L-3

3. To assemble the Fence, align the ⑪ Guide Rods to the machined grooves in the Base of the Router Plane. Thread the ⑭ Flat Head Socket Cap Screws into the adjacent threaded hole while aligning the notch in the Guide Rods. Firmly tighten the Socket Head Cap Screws using the Hex Key. **FIGURE M.**
4. Insert the ⑫ Guide Rod Clamps onto the Guide Rods.
5. Loosely attach each Guide Rod Clamp to the ⑩ Phenolic Fence Plate with the four ⑮ Socket Head Cap Screws.
6. Align the Guide Rod Clamps to the Guide Rods and slide the Fence Assembly onto the Guide Rods.
7. Install the ⑬ Knurled Knobs into the Guide Rod Clamps.
8. Tighten the Socket Head Cap Screws using the Hex Key.
9. To adjust the Fence position, loosen the two Fence Adjustment Knobs, adjust the fence, then re-tighten the Knobs.



III. SHARPENING

1. The Blades can be sharpened while they're installed on the Blade Holder Shaft or removed, whichever is more comfortable for you.
2. The backs of both Blades are lapped flat and polished. The bevel has been carefully ground to the right angle and requires only light honing before use. Hone the bevel on the fine sharpening stone of your choice.
FIGURES N & N-1.
3. **DO NOT** attempt to flatten the bottom. Each Blade is machine-lapped to an extremely strict tolerance and should never need flattening. Use only the finest available abrasive to remove the burr. A leather strop with honing compound is recommended.

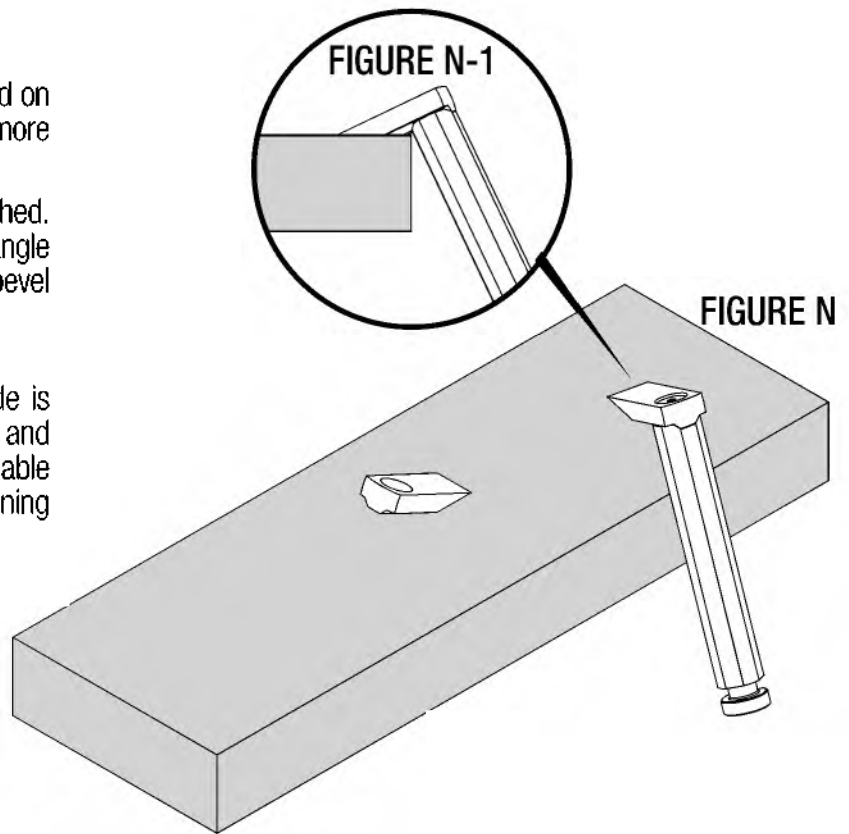



Blue Spruce
TOOLWORKS

Blue Spruce Toolworks, LLC
13700 Prospect Road · Strongsville, OH 44149
877-828-0332

BlueSpruceToolworks.com

© 2024 Blue Spruce Toolworks



WARNING!
This product can expose you to chemicals, including chromium, which is known to the State of California to cause cancer and birth defects or other reproductive harm.
For more information go to www.P65Warnings.ca.gov